

E S O T E C E S O T A R ²



High-End Mobile Loudspeaker Systems

DYNAUDIO
AUTHENTIC FIDELITY

Introduction

Dear Music Lover,

Thank you for your decision to acquire Dynaudio Automotive loudspeakers for aftermarket installation. The Dynaudio Esotec and Esotar² Systems have been developed to the same high standard as the company's renowned home audio, professional studio and multimedia loudspeaker products. The Dynaudio Automotive Esotec and Esotar² ranges are specifically engineered for optimum performance in a vehicle to ensure the most precise in-car music reproduction possible. Dynaudio's advanced technology is the result of many years of intense research and development mated to the highest quality standards in production and the company's enduring passion for musical truth.



Dynaudio is one of very few audio companies producing loudspeaker drivers in-house through its own dedicated development and production departments. All Dynaudio loudspeakers are engineered and manufactured in Denmark from the finest grade materials to the company's extremely high quality standards, and each must pass no less than 86 individual testing stations, representing the most stringent measures in the industry. The state-of-the-art Dynaudio manufacturing facility is so advanced and features such strict quality control measures that Dynaudio is likely to be the only specialty audio company to have exceeded the ISO 9000 quality standard and earn QS 9000 certification.

We wish you many years of enjoying and experiencing music at the highest level of performance,

Dynaudio

About this installation manual

This installation manual provides all technical specifications, installation dimensions and crossover connection instructions for the Dynaudio Esotec and Esotar² series. To realize the full potential of Dynaudio Automotive systems, some areas should be addressed, as touched upon in the following pages.

Due to the great variety of installation conditions it will not offer specific instructions how to install the systems into your car. Please refer to the operating manual of your vehicle or ask your local automotive dealer for further assistance. To observe all relevant matters and thus maximize the tremendous performance potential of your Dynaudio in-car loudspeaker system, consult your authorized Dynaudio Automotive loudspeaker dealer for assistance. Your dealer has the knowledge and expertise to perform a high quality aftermarket installation.

Safety information

As all Dynaudio Esotec and Esotar² Series components are passive (in that they rely on external amplification), the components themselves can not cause any damage.

However, the components can be damaged beyond repair unless a few ground rules are observed:

- ▶ Insure all components are properly installed and wired correctly.
- ▶ Observe the technical specifications.
- ▶ Always use high-quality cabling and amplification.

CAUTION



HIGH SOUND PRESSURE LEVELS

Listening to high sound pressure levels over a prolonged period of time may harm your hearing.

- ▶ To avoid auditory effects do not listen to high sound levels over a long period of time.

Warranty

Dynaudio provides a limited manufacturer's warranty on Dynaudio Automotive aftermarket products. Please check with your local distributor for warranty conditions.



This warranty only covers faults or defects in material and production. Damage caused as a result of abuse, misuse or defective electronics is not covered by the warranty. The warranty will only be valid if the metallic Dynaudio holographic safety label is on the driver.

The warranty is valid only if the product is purchased from an authorized Dynaudio Automotive aftermarket dealer. All warranty claims must be accompanied by a copy of the original purchase invoice and warranties are only valid in the country or market of original origin or distribution. Should warranty service be required, it must be arranged for in the country of purchase by an authorized Dynaudio dealer.

Technical specifications

Tweeters/Midrange

	MD 102	MD 142	Esotar ² 110
Nominal impedance	8 Ω	8 Ω	6 Ω
Recommended frequency range	2200 – 30000 Hz	700 – 6000 Hz	2000 – 30000 Hz
Power handling			
• Nominal long term IEC	100 W	100 W	150 W
• Transient	500 W	1000 W	1000 W
Net weight	0.126 kg	0.75 kg	0.50 kg
Overall dimensions (Ø x D)	62.2 x 43 mm	121 x 66 mm	111 x 41 mm



Woofers

	MW 152	MW 162	MW 162 GT	MW 172	MW 182	Esotar ² 650	Esotar ² 1200
Nominal impedance	4 Ω	4 Ω	4 Ω	4 Ω	4 Ω	4 Ω	4 Ω
Recommended frequency range	55 – 3500 Hz	40 – 4000 Hz	40 – 4000 Hz	35 – 3500 Hz	30 – 2000 Hz	50 – 4000 Hz	18 – 300 Hz
Power handling							
• Nominal long term IEC	100 W	120 W	120 W	150 W	180 W	200 W	400 W
• Transient	1000 W	1000 W	1000 W	1000 W	1000 W	1000 W	1500 W
Net weight	1.1 kg	1.2 kg	1.1 kg	1.3 kg	1.85 kg	1.25 kg	8.8 kg
Overall dimensions (Ø x D)	146 x 70 mm	175 x 77 mm	166 x 71 mm	200 x 88 mm	239 x 86 mm	169 x 78 mm	297 x 162 mm

Esotec crossovers

	X 252	X 362
Crossover frequencies	2200 Hz	900 Hz / 3500 Hz
Nominal impedance	4 Ω	4 Ω
Power handling		
• MW 152	100 W	–
• MW 162/162 GT	120 W	200 W
• MW 172	150 W	200 W
• MW 182	–	200 W
Dimensions	38 x 84 x 145 mm	43 x 104 x 175 mm
Net weight	0.33 kg	0.60 kg



Installation dimensions

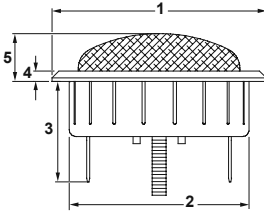
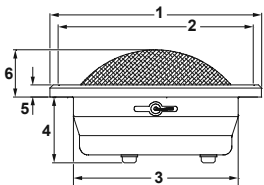
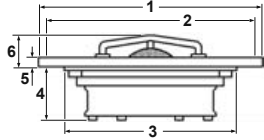

Tweeters/Midrange

	MD 102	MD 142	Esotar ² 110
			
1	max. Ø 62.2 mm	max. Ø 121 mm	Ø 111 mm
2	Mounting hole: Ø 52.1 – 55.5 mm	3 holes: Ø 4 mm on Ø 110.9 mm	6 holes: Ø 4.3 mm on Ø 101 mm
3	29.1 mm	Mounting hole Ø 96 mm (add cut-outs for terminals)	Mounting hole Ø 86 mm
4	3 mm	max. 37.5 mm	27 mm
5	13.86 mm	7.5 mm	max. 4.5 mm
6	–	max. 30 mm	max. 16 mm



Woofers Esotec

	MW 152	MW 162	MW 162 GT	MW 172	MW 182
1	max. Ø 145.5 mm	max. Ø 175 mm	max. Ø 166 mm	max. Ø 200 mm	max. Ø 239 mm
2	6 holes: Ø 4.3 mm on Ø 134.5 mm	6 holes: Ø 4.3 mm on Ø 158 mm	4 holes: Ø 7.5 mm on Ø 155 mm	6 holes: Ø 4.2 mm on Ø 185.75 mm	6 holes: Ø 4.5 mm on Ø 219 mm
3	3 mm	3 mm	Ø 88 mm	4.2 mm	Ø 113 mm
4	Mounting hole min. Ø 124.5 mm	Mounting hole min. Ø 136 mm	Baffle hole min. Ø 134 mm	Mounting hole min. Ø 172 mm	Mounting hole min. Ø 195 mm
5	63 mm	67 mm	62 mm	77.9 mm	75 mm
6	4.3 mm	5 mm	1.5 mm	5.4 mm	5.9 mm
7	13 mm (at max. cone excursion)	15 mm (at max. cone excursion)	15 mm (at max. cone excursion)	17 mm (at max. cone excursion)	16 mm (at max. cone excursion)

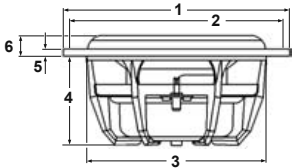
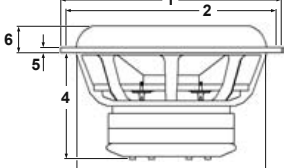

Woofers Esotar²

	Esotar ² 650	Esotar ² 1200
		
1	Ø 169 mm	Ø 297 mm
2	6 holes: Ø 4.3 mm on Ø 158 mm	8 holes: Ø 5.3 mm on Ø 285 mm
3	Mounting hole min. Ø 136 mm	Mounting hole min. Ø 260 mm
4	67 mm	143 mm
5	max. 5.2 mm	max. 7.5 mm
6	15 mm (at max. cone excursion)	35.5 mm (at max. cone excursion)

Impedance correction circuits

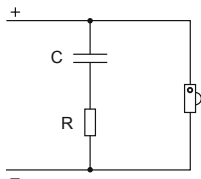

Tweeters/Midrange

	MD 102	MD 142	Esotar ² 110
C	1.2 μ F	1.2 μ F	1.2 μ F
R	8.2 Ω	8.2 Ω	8.2 Ω

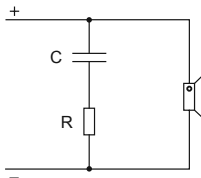

Woofers

	MW 152	MW 162	MW 162 GT	MW 172	MW 182	Esotar ² 650	Esotar ² 1200
C	22 μ F	22 μ F	22 μ F	33 μ F	47 μ F	22 μ F	82 μ F
R	4.7 Ω	4.7 Ω	4.7 Ω	4.7 Ω	4.7 Ω	4.7 Ω	4.7 Ω

Esotar² crossover recommendations

Since the Esotar² speakers are meant to use active filtering, Dynaudio recommends following crossover frequencies:

	Esotar ² 110	Esotar ² 650	Esotar ² 1200
Filter type	high-pass	band-pass	low-pass
Slew rate	-6 dB	-6 dB	-6 dB
Cut-off frequency	2000 Hz	100 Hz and 2000 Hz	100 Hz

Systems overview

Esotec two-way systems

	Bass	Mid	High	Crossover
System 222	MW 152	–	MD 102	X 252
System 242	MW 162	–	MD 102	X 252
System 242 GT	MW 162 GT	–	MD 102	X 252

Esotec three-way systems

	Bass	Mid	High	Crossover
System 342	MW 162	MD 142	MD 102	X 362
System 362	MW 172	MD 142	MD 102	X 362

Esotar² components





	Subwoofer	Mid / Bass	High	Crossover ¹⁾
Components	Esotar ² 1200	Esotar ² 650	Esotar ² 110	Active filtering recommended

1) Please contact your authorized Dynaudio Automotive aftermarket dealer for further information.

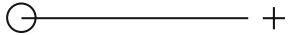
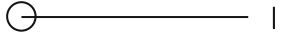
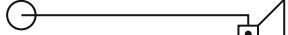

Connecting the Esotec crossovers

2-way crossover X 252

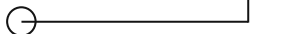
Terminal label		Connections
1		Amplifier 1 To power amplifier: + terminal 2 To power amplifier: - terminal
2		
3		Woofers 3 To woofer: + terminal 4 To woofer: - terminal
4		
5		Tweeter 5 To tweeter: + terminal, +2dB 6 To tweeter: + terminal, ±0dB 7 To tweeter: + terminal, -2dB 8 To tweeter: - terminal
6		
7		
8		

1. To connect the woofer

- ▶ Connect terminal **3** to the **+** terminal of the woofer.
- ▶ Connect terminal **4** to the **-** terminal of the woofer.

2. To connect the tweeter

The terminals **5**, **6** and **7** offer the ability to fine-tune the sound level. This makes it possible to adjust the level according to the placement of the speaker in the car and to your personal preference.

- ▶ Connect terminal **5** or **6** or **7** to the **+** terminal of the tweeter:
 - just use one of the terminals **5**, **6** or **7**
 - start with terminal **6** for the first setup
 - use terminal **5** to **increase** the sound pressure level by 2 dB
 - use terminal **7** to **decrease** the sound pressure level by 2 dB
- ▶ Connect terminal **8** to the **-** terminal of the tweeter.

3. To connect the power amplifier

- ▶ Connect terminal **1** to the **+** terminal of the power amplifier.
- ▶ Connect terminal **2** to the **-** terminal of the power amplifier.

3-way crossover X 362

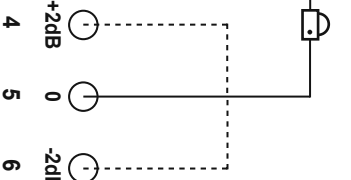
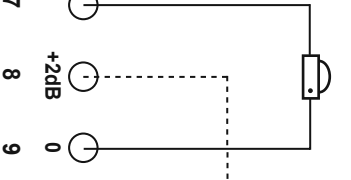
Terminal label	Connections
 <p>1</p> <p>2</p> <p>3</p> <p>4</p> <p>Woofer Amp</p>	<p>1 To woofer: – terminal</p> <p>2 To woofer: + terminal To power amplifier: + terminal</p> <p>3 To power amplifier: – terminal To tweeter: – terminal</p>
 <p>4 +2dB</p> <p>5 0</p> <p>6 -2dB</p> <p>Tweeter</p>	<p>4 To tweeter: + terminal, +2dB</p> <p>5 To tweeter: + terminal, ±0dB</p> <p>6 To tweeter: + terminal, -2dB</p>
 <p>7</p> <p>8 +2dB</p> <p>9 0</p> <p>10 -2dB</p> <p>Midrange</p>	<p>7 To midrange: – terminal</p> <p>8 To midrange: + terminal, +2dB</p> <p>9 To midrange: + terminal, ±0dB</p> <p>10 To midrange: + terminal, -2dB</p>

1. To connect the woofer

- ▶ Connect terminal **1** to the **-** terminal of the woofer.
- ▶ Connect terminal **2** to the **+** terminal of the woofer.

2. To connect the tweeter

The terminals **4**, **5** and **6** offer the ability to fine-tune the sound level. This makes it possible to adjust the level according to the placement of the speaker in the car and to your personal preference.

- ▶ Connect terminal **3** to the **-** terminal of the tweeter.
- ▶ Connect terminal **4** or **5** or **6** to the **+** terminal of the tweeter.
 - just use one of the terminals **4**, **5** or **6**
 - start with terminal **5** for the first setup
 - use terminal **4** to **increase** the sound pressure level by 2 dB
 - use terminal **6** to **decrease** the sound pressure level by 2 dB

3. To connect the midrange

The terminals **8**, **9** and **10** offer the ability to fine-tune the sound level. This makes it possible to adjust the level according to the placement of the speaker in the car and to your personal preference.

- ▶ Connect terminal **7** to the **-** terminal of the midrange.
- ▶ Connect terminal **8** or **9** or **10** to the **+** terminal of the midrange.
 - just use one of the terminals **8**, **9** or **10**
 - start with terminal **9** for the first setup
 - use terminal **8** to **increase** the sound pressure level by 2 dB
 - use terminal **10** to **decrease** the sound pressure level by 2 dB

4. To connect the power amplifier

- ▶ Connect terminal **2** to the **+** terminal of the power amplifier.
- ▶ Connect terminal **3** to the **-** terminal of the power amplifier.



Dynaudio A/S, 8660 Skanderborg, Denmark

Sales & Marketing

Dynaudio International GmbH, Ohepark 2, 21224 Rosengarten, Germany, Phone +49 - 4108 - 4180 - 0

www.dynaudio.com